

Rainwater Harvesting

Introduction

A sufficient, clean drinking water supply is essential to life. Millions of people throughout the world still do not have access to this basic necessity. After decades of work by governments and organisations to bring potable water to the poorer people of the world, the situation is still dire. The reasons are many and varied but generally speaking, the poor of the world cannot afford the capital intensive and technically complex traditional water supply systems which are widely promoted by governments and agencies throughout the world. Rainwater harvesting (RWH) is an option that has been adopted in many areas of the world where conventional water supply systems have failed to meet peoples needs. It is a technique that has been used since antiquity.



Figure 1: Sigiriya, Sri Lanka. This reservoir cut into the rock was used centuries ago to hold harvested rainwater.

Examples of RWH systems can be found in all the great civilisations throughout history. In industrialised countries, sophisticated RWH systems have been developed with the aim of reducing water bills or to meet the needs of remote communities or individual households in arid regions. Traditionally, in Uganda and Sri Lanka, for example, rainwater is collected from trees, using banana leaves or stems as temporary gutters; up to 200 litres may be collected from a large tree in a single storm. Many individuals and groups have taken the initiative and developed a wide variety of RWH systems throughout the world.

It is worth distinguishing, between the various types of RWH practised throughout the world. RWH has come to mean the control or utilisation of rainwater close to the point rain reaches the earth. Its practice effectively divides into

- Domestic RWH
- RWH for agriculture, erosion control, flood control and aquifer replenishment.

It is worth bearing in mind that rainwater harvesting is not the definitive answer to household water problems. There is a complex set of inter-related circumstances that have to be considered when choosing the appropriate water source. These include cost, climate, hydrology, social and political elements, as well as technology, all play a role in the eventual

Knowledge and Information Services, The Schumacher Centre for Technology & Development

Bourton Hall, Bourton-on-Dunsmore, Rugby, Warwickshire CV23 9QZ, UK

Tel+44 (0)1926 634460 Fax +44 (0)1926 634401 E-mail info@itdg.org Web <http://www.itdg.org>

**Intermediate Technology Development Group Ltd Patent HRH - The Prince of Wales, RG, KT, GCB
 Company Reg. No 271054, England Reg. Charity No 247287 VAT No 241 5154 82**

technical note

choice of water supply scheme that is adopted for a given situation. RWH is only one possible choice, but one that is often overlooked by planners, engineers and builders.

The reason that RWH is rarely considered is often due to lack of information – both technical and otherwise. In many areas where RWH has been introduced as part of a wider drinking water supply programme, it was at first unpopular, simply because little was known about the technology by the beneficiaries. In most of these cases, the technology has quickly gained popularity as the user realises the benefits of a clean, reliable water source at the home. the town supply is unreliable or where local water sources dry up for a part of the year, but is also In many cases RWH has been introduced as part of an integrated water supply system, where often used as the sole water source for a community or household. It is a technology that is flexible and adaptable to a very wide variety of conditions, being used in the richest and the poorest societies on our planet, and in the wettest and the driest regions of the world.

Components of a Domestic RWH system

DRWH systems vary in complexity, some of the traditional Sri Lankan systems are no more than a pot situated under a piece of cloth or plastic sheet tied at its corners to four poles. The cloth captures the water and diverts it through a hole in its centre into the pot. Some of the sophisticated systems manufactured in Germany incorporate clever computer management systems, submersible pumps, and links into the grey water and mains domestic plumbing systems. Somewhere between these two extremes we find the typical DRWH system used in a developing country scenario. Such a system will usually comprise a collection surface (a clean roof or ground area), a storage tank, and guttering to transport the water from the roof to the storage tank. Other peripheral equipment is sometimes incorporated, for example: first flush systems to divert the dirty water which contains roof debris after prolonged dry periods; filtration equipment and settling chambers to remove debris and contaminants before water enters the storage tank or cistern; handpumps for water extraction; water level indicators, etc.

Typical Domestic RWH Systems.

Storage tanks and cisterns

The water storage tank usually represents the biggest capital investment element of a domestic RWH system. It therefore usually requires careful design – to provide optimal storage capacity while keeping the cost as low as possible. The catchment area is usually the existing rooftop or occasionally a cleaned area of ground, as seen in the courtyard collection systems in China, and guttering can often be obtained relatively cheaply, or can be manufactured locally.

There are an almost unlimited number of options for storing water. Common vessels used for very small-scale water storage in developing countries include such examples as plastic bowls and buckets, jerrycans, clay or ceramic jars, cement jars, old oil drums, empty food containers, etc. For storing larger quantities of water the system will usually require a tank or a cistern. For the purpose of this document we will classify the tank as an above-ground storage vessel and the cistern as a below-ground storage vessel. These can vary in size from a cubic metre or so (1000 litres) up to hundreds of cubic metres for large projects, but typically up to a maximum of 20 or 30 cubic metres for a domestic system. The choice of system will depend on a number of technical and economic considerations listed below.

- Space availability
- Options available locally
- Local traditions for water storage
- Cost – of purchasing new tank
- Cost – of materials and labour for construction
- Materials and skills available locally
- Ground conditions
- Style of RWH – whether the system will provide total or partial water supply

technical note

One of the main choices will be whether to use a tank or a cistern. Both tanks and cisterns have their advantages and disadvantages. Table 1 summarises the pros and cons of each.

	Tank	Cistern
Pros	<ul style="list-style-type: none"> • Above ground structure allows easy inspection for leakages • Many existing designs to choose from • Can be easily purchased 'off-the-shelf' • Can be manufactured from a wide variety of materials • Easy to construct from traditional materials • Water extraction can be by gravity in many cases • Can be raised above ground level to increase water pressure 	<ul style="list-style-type: none"> • Generally cheaper due to lower material requirements • More difficult to empty by leaving tap on • Require little or no space above ground • Unobtrusive • Surrounding ground gives support allowing lower wall thickness and thus lower costs
Cons	<ul style="list-style-type: none"> • Require space • Generally more expensive • More easily damaged • Prone to attack from weather • Failure can be dangerous 	<ul style="list-style-type: none"> • Water extraction is more problematic – often requiring a pump • Leaks are more difficult to detect • Contamination of the cistern from groundwater is more common • Tree roots can damage the structure • There is danger to children and small animals if the cistern is left uncovered • Flotation of the cistern may occur if groundwater level is high and cistern is empty. • Heavy vehicles driving over a cistern can cause damage

Table 1: Pros and Cons of Tanks and Cisterns



Figure 3: a) An owner built brick tank in Sri Lanka. b) A corrugated iron RWH tank in Uganda.

Much work has been carried out to develop the ideal domestic RWH tank. The Case Studies later in this document show a variety of tanks that have been built in different parts of the world.

Collection surfaces

For domestic rainwater harvesting the most common surface for collection is the roof of the dwelling. Many other surfaces can be, and are, used: courtyards, threshing areas, paved walking areas, plastic sheeting, trees, etc. In some cases, as in Gibraltar, large rock

technical note

surfaces are used to collect water which is then stored in large tanks at the base of the rock slopes.



Figure 4: A typical corrugated iron sheet roof showing guttering

Most dwellings, however, have a roof. The style, construction and material of the roof affect its suitability as a collection surface for water. Typical materials for roofing include corrugated iron sheet, asbestos sheet; tiles (a wide variety is found), slate, and thatch (from a variety of organic materials). Most are suitable for collection of roofwater, but only certain types of grasses e.g. coconut and anahaw palm (Gould and Nissen Peterson, 1999), thatched tightly, provide a surface adequate for high quality water collection. The rapid move towards the use of corrugated iron sheets in many developing countries favours the promotion of RWH (despite the other negative attributes of this material).

Guttering

Guttering is used to transport rainwater from the roof to the storage vessel. Guttering comes in a wide variety of shapes and forms, ranging from the factory made PVC type to home made guttering using bamboo or folded metal sheet. In fact, the lack of standards in guttering shape and size makes it difficult for designers to develop standard solutions to, say, filtration and first flush devices. Guttering is usually fixed to the building just below the roof and catches the water as it falls from the roof.

Below are shown some of the common types of guttering and fixings.

technical note

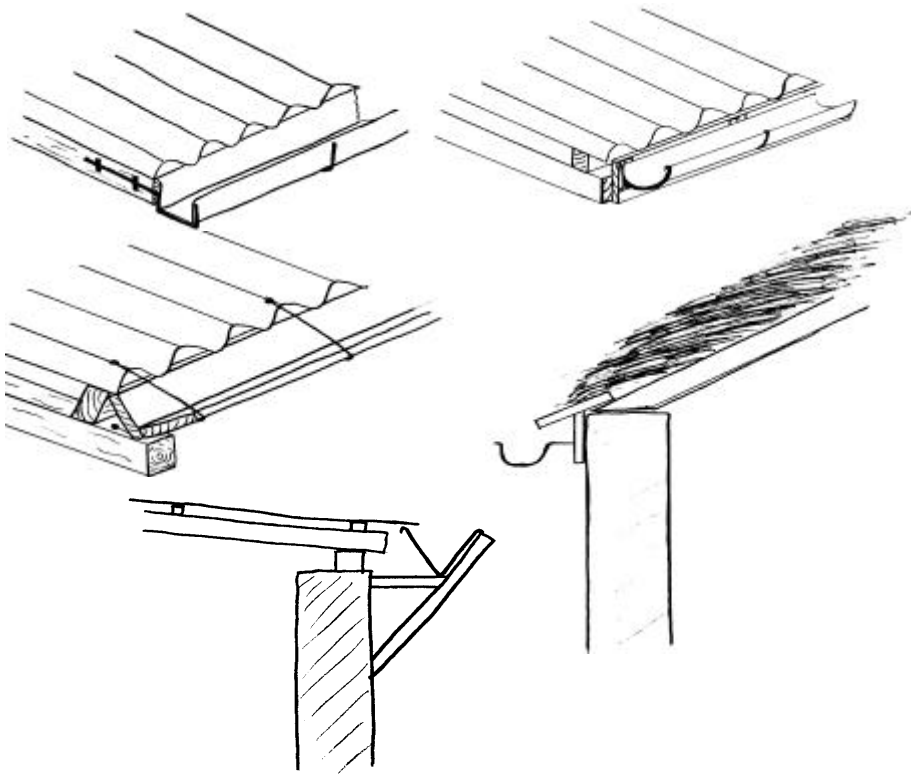

Figure 5: a variety of guttering types showing possible fixings

Manufacture of low-cost gutters

Factory made gutters are usually expensive and beyond the reach of the poor of developing countries, if indeed available at all in the local marketplace. They are seldom used for very low-cost systems. The alternative is usually to manufacture gutters from materials that can be found cheaply in the locality. There are a number of techniques that have been developed to help meet this demand; one such technique is described below.

V-shaped gutters from galvanised steel sheet can be made simply by cutting and folding flat galvanised steel sheet. Such sheet is readily available in most market centres (otherwise corrugated iron sheet can be beaten flat) and can be worked with tools that are commonly found in a modestly equipped workshop. One simple technique is to clamp the cut sheet between two lengths of straight timber and then to fold the sheet along the edge of the wood. A strengthening edge can be added by folding the sheet through 90° and then completing the edge with a hammer on a hard flat surface. The better the grade of steel sheet that is used, the more durable and hard wearing the product. Fitting a downpipe to V-shaped guttering can be problematic and the V-shaped guttering will often be continued to the tank rather than changing to the customary circular pipe section downpipe. Methods for fixing gutters are shown in figure 5.

technical note

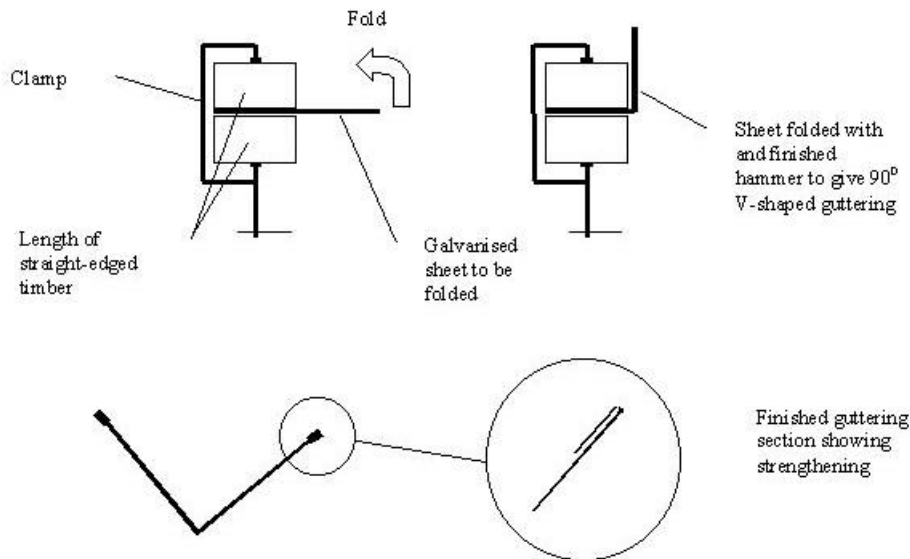

Figure 6: folding galvanised steel sheet to make V-shaped guttering

First flush systems

Debris, dirt, dust and droppings will collect on the roof of a building or other collection area. When the first rains arrive, this unwanted matter will be washed into the tank. This will cause contamination of the water and the quality will be reduced. Many RWH systems therefore incorporate a system for diverting this ‘first flush’ water so that it does not enter the tank.

The simpler ideas are based on a manually operated arrangement whereby the inlet pipe is moved away from the tank inlet and then replaced again once the initial first flush has been diverted. This method has obvious drawbacks in that there has to be a person present who will remember to move the pipe.

Other systems use tipping gutters to achieve the same purpose. The most common system (as shown in Figure 7a) uses a bucket which accepts the first flush and the weight of this water off-balances a tipping gutter which then diverts the water back into the tank. The bucket then empties slowly through a small-bore pipe and automatically resets. The process will repeat itself from time to time if the rain continues to fall, which can be a problem where water is really at a premium. In this case a tap can be fitted to the bucket and will be operated manually. The quantity of water that is flushed is dependent on the force required to lift the guttering. This can be adjusted to suit the needs of the user.

Figure 7 – a) the tipping gutter first flush system and b) the floating ball first flush system

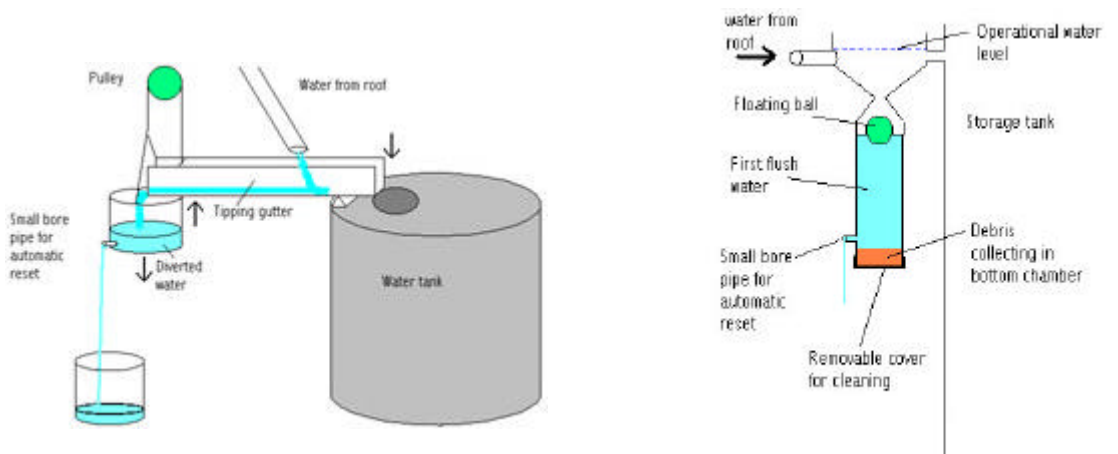

technical note

Another system that is used relies on a floating ball that forms a seal once sufficient water has been diverted (see Figure 7b). The seal is usually made as the ball rises into the apex of an inverted cone. The ball seals the top of the 'waste' water chamber and the diverted water is slowly released, as with the bucket system above, through a small bore pipe. Again, the alternative is to use a tap. In some systems (notably one factory manufactured system from Australia) the top receiving chamber is designed such that a vortex is formed and any particles in the water are drawn down into the base of the vortex while only clean water passes into the storage tank. The 'waste' water can be used for irrigating garden plants or other suitable application. The debris has to be removed from the lower chamber occasionally.

Although the more sophisticated methods provide a much more elegant means of rejecting the first flush water, practitioners often recommend that very simple, easily maintained systems be used, as these are more likely to be repaired if failure occurs.

Filtration systems and settling tanks

Again, there are a wide variety of systems available for treating water before, during and after storage. The level of sophistication also varies, from extremely high-tech to very rudimentary.

A German company, WISY, have developed an ingenious filter which fits into a vertical downpipe and acts as both filter and first-flush system. The filter, shown in Figure 8, cleverly takes in water through a very fine (~0.20mm) mesh while allowing silt and debris to continue down the pipe. The efficiency of the filter is over 90%. This filter is commonly used in European systems.

The simple trash rack has been used in some systems but this type of filter has a number of associated problems: firstly it only removes large debris; and secondly the rack can become clogged easily and requires regular cleaning.

The sand-charcoal-stone filter is often used for filtering rainwater entering a tank. This type of filter is only suitable, however, where the inflow is slow to moderate, and will soon overflow if the inflow exceeds the rate at which the water can percolate through the sand. Settling tanks and partitions can be used to remove silt and other suspended

solids from the water. These are usually effective where used, but add significant additional cost if elaborate techniques are used. Many systems found in the field rely simply on a piece of cloth or fine mosquito mesh to act as the filter (and to prevent mosquitoes entering the tank).

Post storage filtration include such systems as the upflow sand filter or the twin compartment candle filters commonly found in LDC's. Many other systems exist and can be found in the appropriate water literature.

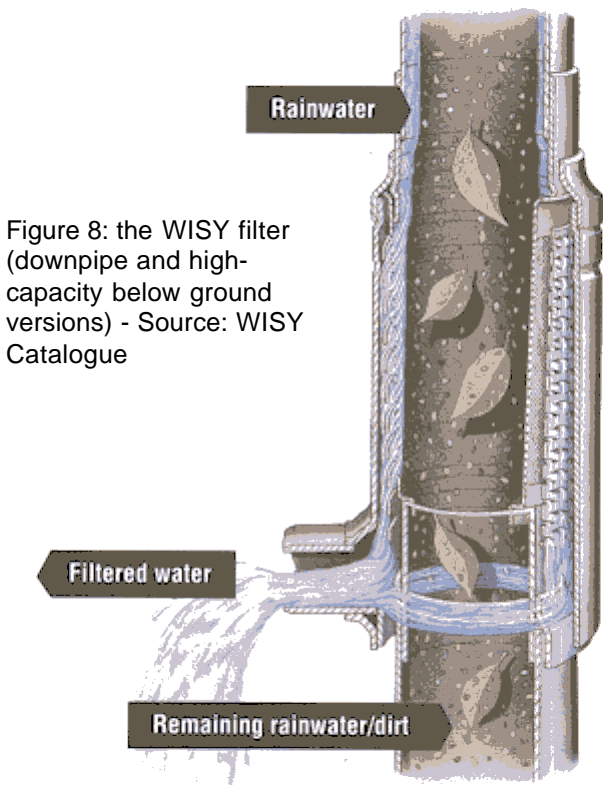

Figure 8: the WISY filter (downpipe and high-capacity below ground versions) - Source: WISY Catalogue

technical note

Sizing the system

Usually, the main calculation carried out by the designer when planning a domestic RWH system will be to size the water tank correctly to give adequate storage capacity. The storage requirement will be determined by a number of interrelated factors. They include:

- local rainfall data and weather patterns
- size of roof (or other) collection area
- runoff coefficient (this varies between 0.5 and 0.9 depending on roof material and slope)
- user numbers and consumption rates

The style of rainwater harvesting i.e. whether the system will provide total or partial supply (see the next section) will also play a part in determining the system components and their size.

There are a number of different methods used for sizing the tank. These methods vary in complexity and sophistication. Some are readily carried out by relatively inexperienced, first-time practitioners while others require computer software and trained engineers who understand how to use this software. The choice of method used to design system components will depend largely on the following factors:

- the size and sophistication of the system and its components
- the availability of the tools required for using a particular method (e.g. computers)
- the skill and education levels of the practitioner / designer

Below we will outline 3 different methods for sizing RWH system components.

Method 1 – demand side approach

A very simple method is to calculate the largest storage requirement based on the consumption rates and occupancy of the building.

As a simple example we can use the following typical data:

Consumption per capita per day, $C = 20$ litres

Number of people per household, $n = 6$

Longest average dry period = 25 days

Annual consumption = $C \times n = 120$ litres

Storage requirement, $T = 120 \times 25 = 3,000$ litres

This simple method assumes sufficient rainfall and catchment area, and is therefore only applicable in areas where this is the situation. It is a method for acquiring rough estimates of tank size.

Method 2 – supply side approach

In low rainfall areas or areas where the rainfall is of uneven distribution, more care has to be taken to size the storage properly. During some months of the year, there may be an excess of water, while at other times there will be a deficit. If there is enough water throughout the year to meet the demand, then sufficient storage will be required to bridge the periods of scarcity. As storage is expensive, this should be done carefully to avoid unnecessary expense. This is a common scenario in many developing countries where monsoon or single wet season climates prevail.

The example given here is a simple spreadsheet calculation for a site in North Western Tanzania. The rainfall statistics were gleaned from a nurse at the local hospital who had been keeping records for the previous 12 years. Average figures for the rainfall data were used to simplify the calculation, and no reliability calculation is done. This is a typical field approach to RWH storage sizing.

The example is taken from a system built at a medical dispensary in the village of Ruganzu, Biharamulo District, Kagera, Tanzania in 1997.

<p>Demand: Number of staff: 6 Staff consumption: 25 lpcd* Patients: 30 Patient consumption : 10 lpcd Total daily demand: 450 litres</p>	<p>Supply: Roof area: 190m² Runoff coefficient** (for new corrugated GI roof): 0.9 Average annual rainfall: 1056mm per year Daily available water (assuming all is collected) = $(190 \times 1056 \times 0.9) / 365 = 494.7$ litres</p>
---	---

*lpcd – litres per capita per day

** Run-off coefficient values vary between 0.3 and 0.9 depending on the material of the catchment area. It takes into consideration losses due to percolation, evaporation, etc.

In this case, it was decided to size the tank to suit the supply, assuming that there may be growth in numbers of patients or staff in the future. Careful water management will still be required to ensure water throughout the year.

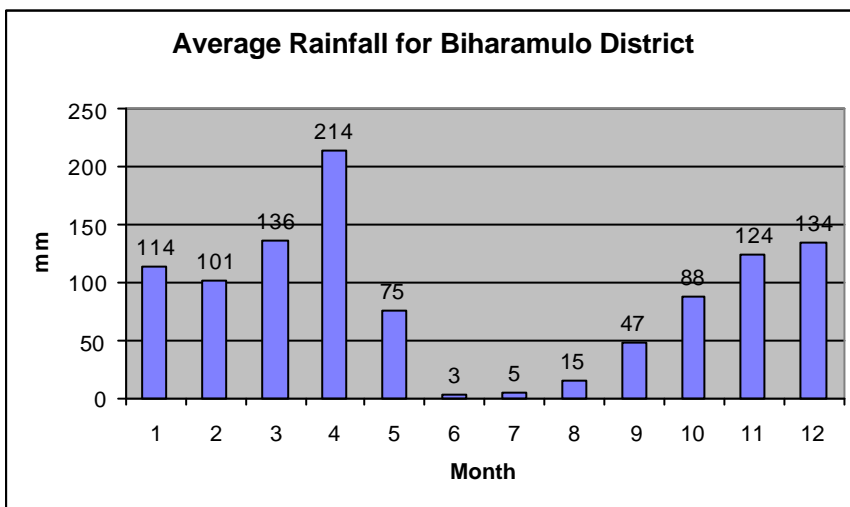
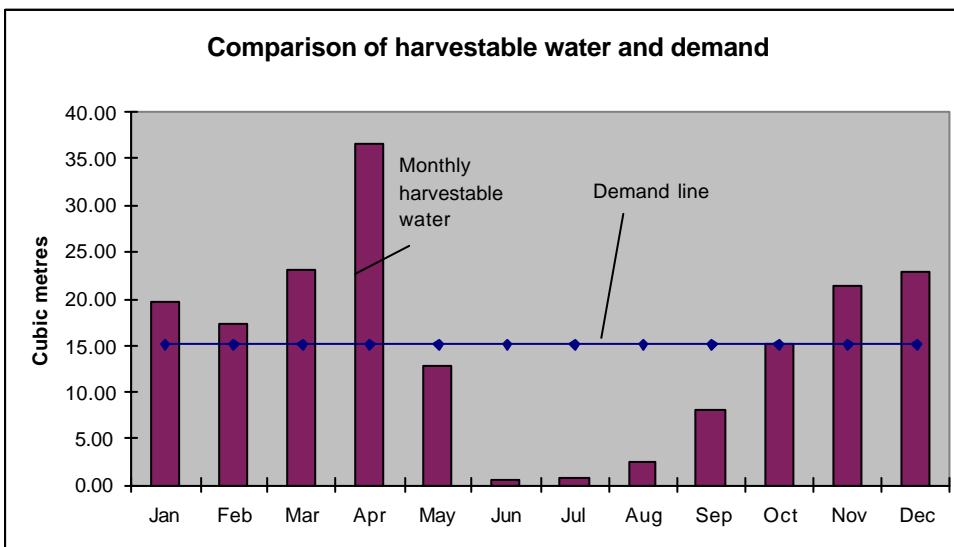

Figure 9: Average monthly rainfall for Biharamulo District

Figure 10 shows the comparison of water harvested and the amount that can be supplied to the dispensary using all the water which is harvested. It can be noted that there is a single rainy season. The first month that the rainfall on the roof meets the demand is October. If we therefore assume that the tank is empty at the end of September we can form a graph of cumulative harvested water and cumulative demand and from this we can calculate the maximum storage requirement for them dispensary.

Figure 10: Comparison of the harvestable water and the demand for each month.



technical note

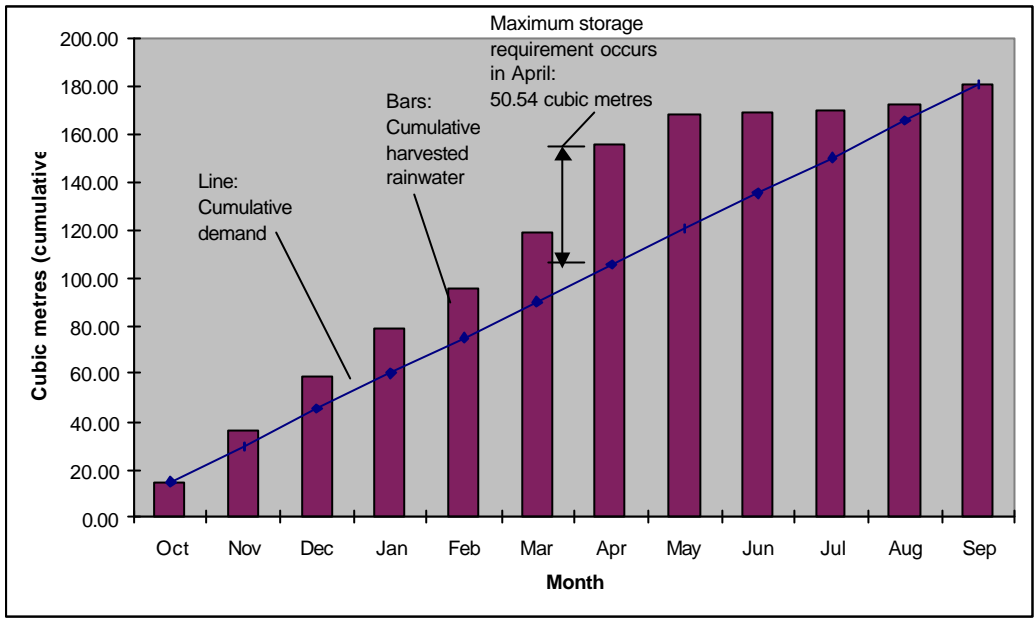

Figure11: showing the predicted cumulative inflow and outflow from the tank. The maximum storage requirement occurs in April at 50.45 cubic metres. All this water will have to be stored to cover the shortfall during the dry period.

In this case the solution was a 50 cubic metre ferrocement tank.



Figure 12: Ferrocement tank in Ruganzu Village

Method 3 – computer model

There are several computer-based programmes for calculating tank size quite accurately. One such programme, known as SimTanka, has been written by an Indian organisation and is available free of charge on the World Wide Web. The Ajit Foundation is a registered non-profit voluntary organisation with its main office in Jaipur, India and its community resource centre in Bikaner, India.

technical note

SimTanka is a software programme for simulating performance of rainwater harvesting systems with covered water storage tank. Such systems are called Tanka in western parts of the state of Rajasthan in India. The idea of this computer simulation is to predict the performance of a rainwater harvesting system based on the mathematical model of the actual system. In particular SimTanka simulates the fluctuating rainfall on which the rainwater harvesting system is dependent.

SimTanka requires at least 15 years of monthly rainfall records for the place at which the rainwater harvesting system is located. If you do not have the rainfall record for the place then the rainfall record from the nearest place which has the same pattern of rainfall can be used. The software will then calculate optimum storage size or catchment size depending on the requirements of the user. SimTanka also calculates the reliability of the system based on the rainfall data of the previous 15 years. See the resources section for the Web Site address.

Further comments

The methods outlined above can be further refined, where necessary, to use daily rainfall data. This is particularly important in areas where rainfall is more evenly distributed and more sensitive calculations are necessary.

Rainfall data can be obtained from a variety of sources. The first point of call should be the national meteorological organisation for the country in question. In some developing countries, however, statistics are limited due to lack of resources and other sources are often worth seeking. Local Water Departments or local organisations, local hospitals or schools are all possible sources of information.

In reality the cost of the tank materials will often govern the choice of tank size. In other cases, such as large RWH programmes, standard sizes of tank are used regardless of consumption patterns, roof size or number of individual users (although the tank size will, hopefully, be based on local averages).

User behaviour patterns with domestic RWH
Styles of RWH – system, climate and geographical variables

Rainwater that has been harvested is used in many different ways. In some parts of the world it is used merely to capture enough water during a storm to save a trip or two to the main water source. Here, only small storage capacity is required, maybe just a few small pots to store enough water for a day or half a day. At the other end of the spectrum we see, in arid areas of the world, systems which have sufficient collection surface area and storage capacity to provide enough water to meet the full needs of the user. Between these two extremes exists a wide variety of different user patterns or regimes. There are many variables that determine these patterns of usage for RWH. Some of these are listed below:



Figure 13: small jars used in Cambodia as part of a multi-sourced water supply

technical note

- *Rainfall quantity (mm/year)*
- *Rainfall pattern* - The type of rainfall pattern, as well as the total rainfall, which prevails will often determine the feasibility of a RWHS. A climate where rain falls regularly throughout the year will mean that the storage requirement is low and hence the system cost will be correspondingly low and vice versa. More detailed rainfall data is required to ascertain the rainfall pattern. The more detailed the data available, the more accurately the system parameters can be defined.
- *Collection surface area (m^2)*
- *Available storage capacity (m^3)*
- *Daily consumption rate (litres/capita /day or lpcd)* - this varies enormously – from 10 – 15 lpcd a day in some parts of Africa to several hundred lpcd in some industrialised countries. This will have obvious impacts on system specification.
- *Number of users* - again this will greatly influence the requirements.
- *Cost* – a major factor in any scheme.
- *Alternative water sources* – where alternative water sources are available, this can make a significant difference to the usage pattern. If there is a groundwater source within walking distance of the dwelling (say within a kilometre or so), then a RWHS that can provide a reliable supply of water at the homestead for the majority of the year, will have a significant impact to lifestyle of the user. Obviously, the user will still have to cart water for the remainder of the year, but for the months when water is available at the dwelling there is a great saving in time and energy. Another possible scenario is where rainwater is stored and used only for drinking and cooking, the higher quality water demands, and a poorer quality water source, which may be near the dwelling, is used for other activities.
- *Water management strategy* – whatever the conditions, a careful water management strategy is always a prudent measure. In situations where there is a strong reliance on stored rainwater, there is a need to control or manage the amount of water being used so that it does not dry up before expected.

We can simply classify most systems by the amount of 'water security' or 'reliability' afforded by the system. There are four types of user regimes listed below:

Occasional - water is collected occasionally with a small storage capacity, which allows the user to store enough water for a maximum of, say, one or two days. This type of system is ideally suited to a climate where there is a uniform, or bimodal, rainfall pattern with very few dry days during the year and where an alternative water source is available nearby.

Intermittent – this type of pattern is one where the requirements of the user are met for a part of the year. A typical scenario is where there is a single long rainy season and, during this time, most or all of the users' needs are met. During the dry season, an alternative water source has to be used or, as we see in the Sri Lankan case, water is carted/ bowsered in from a nearby river and stored in the RWH tank. Usually, a small or medium size storage vessel is required to bridge the days when there is no rain.

Partial – this type of pattern provides for partial coverage of the water requirements of the user during the whole of the year. An example of this type of system would be where a family gather rainwater to meet only the high-quality needs, such as drinking or cooking, while other needs, such as bathing and clothes washing, are met by a water source with a lower quality.

Full – with this type of system the total water demand of the user is met for the whole of the year by rainwater only. This is sometimes the only option available in areas where other sources are unavailable. A careful feasibility study must be carried out before hand to ensure that conditions are suitable. A strict water management strategy is required when such a system is used to ensure that the water is used carefully and will last until the following wet season.

technical note

Rainwater quality and Health

Rainwater is often used for drinking and cooking and so it is vital that the highest possible standards are met. Rainwater, unfortunately, often does not meet the World Health Organisation (WHO) water quality guidelines. This does not mean that the water is unsafe to drink. Gould and Nissen-Peterson(1999), in their recent book, point out that the Australian government have given the all clear for the consumption of rainwater 'provided the rainwater is clear, has little taste or smell, and is from a well-maintained system'. It has been found that a favourable user perception of rainwater quality (not necessarily perfect water quality) makes an enormous difference to the acceptance of RWH as a water supply option.

Generally the chemical quality of rainwater will fall within the WHO guidelines and rarely presents problems. There are two main issues when looking at the quality and health aspects of DRWH:

Firstly, there is the issue of *bacteriological water quality*. Rainwater can become contaminated by faeces entering the tank from the catchment area. It is advised that the catchment surface always be kept clean. Rainwater tanks should be designed to protect the water from contamination by leaves, dust, insects, vermin, and other industrial or agricultural pollutants. Tanks should be sited away from trees, with good fitting lids and kept in good condition. Incoming water should be filtered or screened, or allowed to settle to take out foreign matter (as described in a previous section). Water which is relatively clean on entry to the tank will usually improve in quality if allowed to sit for some time inside the tank. Bacteria entering the tank will die off rapidly if the water is relatively clean. Algae will grow inside a tank if sufficient sunlight is available for photosynthesis. Keeping a tank dark and sited in a shady spot will prevent algae growth and also keep the water cool. As mentioned in a previous section, there are a number of ways of diverting the dirty 'first flush' water away from the storage tank. The area surrounding a RWH should be kept in good sanitary condition, fenced off to prevent animals fouling the area or children playing around the tank. Any pools of water gathering around the tank should be drained and filled.

Gould points out that in a study carried out in north-east Thailand 90 per cent of in-house storage jars were contaminated whilst only 40% of the RWH jars were contaminated. This suggests secondary contamination (through poor hygiene) is a major cause of concern.

Secondly, there is a need to prevent insect vectors from breeding inside the tank. In areas where malaria is present, providing water tanks without any care for preventing insect breeding, can cause more problems than it solves. All tanks should be sealed to prevent insects from entering. Mosquito proof screens should be fitted to all openings. Some practitioners recommend the use of 1 to 2 teaspoons of household kerosene in a tank of water which provides a film to prevent mosquitoes settling on the water.

There are several simple methods of treatment for water before drinking.

- Boiling water will kill any harmful bacteria which may be present
- Adding chlorine in the right quantity (35ml of sodium hypochlorite per 1000 litres of water) will disinfect the water
- Slow sand filtration will remove any harmful organisms when carried out properly
- A recently developed technique called SODIS (SOlar DISinfection) utilises plastic bottles which are filled with water and placed in the sun for one full day. The back of the bottle is painted black. More information can be found through the Resource Section at the end of this document.

Domestic Roof Water Harvesting Systems – some Case Studies

Case Study 1 - The Sri Lankan Pumpkin Tank

Background Information

The Sri Lankan Pumpkin Tank, and the associated construction technique, was developed as part of a World Bank sponsored Water and Sanitation Programme which was implemented in the country between 1995 and 1998. The Community Water Supply and Sanitation Programme (CWSSP) covered 3 districts within the country – Badulla, Ratnapura and Matara Districts. Hundreds of these tanks were built in areas where conventional supply schemes, such as piped supplies or groundwater supplies, were difficult to provide. In some areas members of the target community were given the choice of a RWH system for individual households or a groundwater supply for a group of households. The choice varied. In all cases there was a choice of type of tank – either the Pumpkin tank or an underground tank. The choice was usually a function of ground conditions rather than personal preference. Both tanks have a capacity of approximately 5m³.

The Abikon family of Demetaralhina in Badulla District chose a pumpkin tank. Their village is in a rural highlands area of the country and the ground conditions were not suitable for a groundwater supply or for digging a pit for a below ground tank. Average annual rainfall is 2250mm with a bimodal rainfall pattern (two wet seasons) and the longest dry period usually between December and April. Their per capita consumption was well below the 20 litres per day that each family member now consumes. The water is used for drinking (but only after

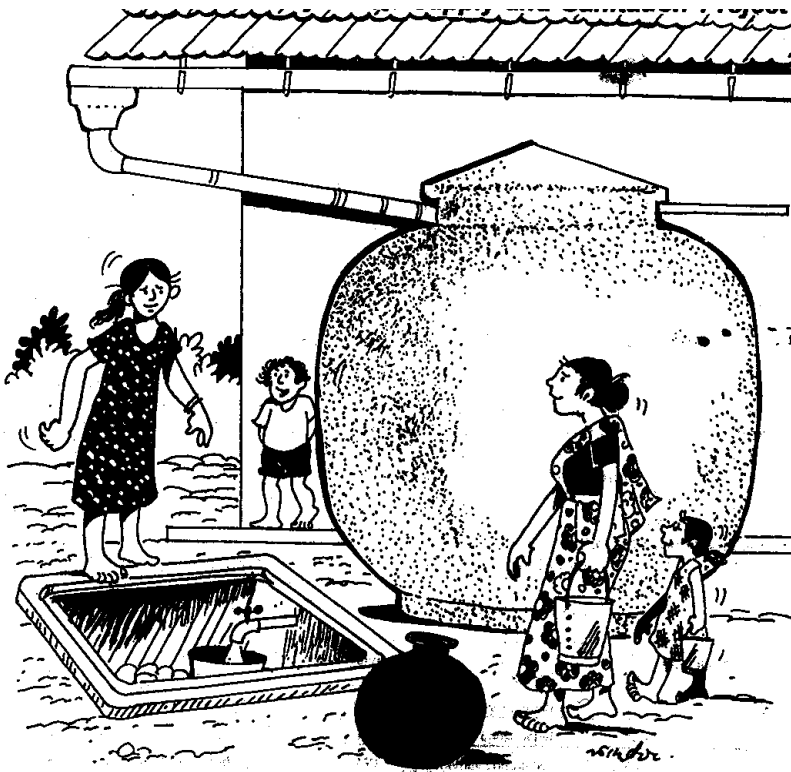

boiling), cooking, personal and clothes washing. Mr Abikon also uses the water from their tank to water their 4 cows. Only towards the end of the dry season does the tank sometimes dry up and then the family has to walk to the spring, about ½ a mile from their home.

technical note



Figure 14: a) One of the 10 legs used to form the skeleton frame. b) The skeleton frame being rendered.

Technical details

Rainwater is collected from only 1 side of the pitched roof, a collection area of 32m². The roofing material is a mix of zinc and asbestos sheeting. The guttering is a PVC U-channel, factory manufactured, found commonly in the nearby town, fitted to a fascia board with similarly manufactured brackets, spaced at 300mm centres. The downpipe is a standard 3" PVC pipe, although some of the neighbours use less costly downpipes made from string and plastic tubing. The cost of the guttering is approximately SLR5,600, about Sterling £86.00.

This pumpkin tank was built 3 years ago and is in very good condition. The construction is of ferrocement. The construction detail is given later. The cost of the tank is approximately SLR5,000 or Sterling £77.00. The materials and specialist labour for the tank were provided by CWSSP and the guttering was purchased by the Abikon family.

Water extraction is through a tap piped to a point slightly away from the tank, where the ground falls away and allows a bucket to be placed easily under the tap. There is a first flush mechanism fitted in the form of a simple PVC elbow with a length of pipe which diverts the dirty first water away from the inlet chamber. The inlet chamber also acts as the pre-filter chamber. The chamber is approximately 600mm cubed and contains subsequent layers of stone, charcoal and sand, through which rainwater passes.

Construction details:

The following construction details are given in the instructions that are handed out to masons during their training session:

1. Prepare skeleton / framework legs (Figure 14) as shown in the drawing. 10 no. required. Prepare the crown ring. This can be used again for many tanks.
2. Lay the concrete base using two layers of chicken wire as reinforcing. Allow 300mm of chicken wire to protrude all around the edge of the base. This will be connected to the wall mesh later. Lay 10 anchor bolts for the legs in the base while casting (the diameter will depend on the diameter of the holes in the legs).
3. Leave the base for 7 days to cure, wetting each day.
4. Secure the 10 skeleton legs using the bolts and the crown ring.
5. Take 6mm steel rod and wrap it around the outside of the legs, starting at the bottom and working up at 10cm intervals.

technical note

6. Fix 2 layers of chicken wire over the outside of the skeleton. The filter tower can be added at this point if a filter is to be fitted.
7. Plaster the outside of the mesh. Leave for 1 day.
8. Go inside the tank and remove the skeleton.
9. Plaster inside the tank and cure for 7 days.

Water proofing can be added to the mortar. This can be a specialist additive or liquid dishwashing soap.

Cure the tank by wetting for 7 – 10 days. Fill the gradually starting on day 7, filling at a rate of approximately 300mm per day.



Figure 15: A finished Pumpkin tank

Materials and labour breakdown

Material	Unit	Qty	Unit Cost	Total cost
Cement	50kg bag	8	265	2120
Sand	ft ³	55	3.5	192.5
Metal	ft ³	6	18	108
½" Chicken Mesh	ft ²	366	4	1464
Mould		1	325*	325
Transport				500
Skilled labour	hr	56	22	1232
Unskilled labour	hr	112	12.5	1400
				7341.5

*Assuming mould is used for 10 tanks
 All costs given in Sri Lankan Rupees
 (65 SL Rupees = Sterling £1.00 at the time of writing)

Case Study 2 – The underground brick dome tank (5m³), Sri Lanka

This is another RWH system, as with the previous case study, which was developed by the CWSSP programme in Sri Lanka. The tank, a 5m³ underground brick built tank, is based loosely on the design of the Chinese below ground biogas tank. Indeed, the Sri Lankan

technical note

engineer who designed the system had studied for some years in China. This is a good example of cross fertilisation of technologies across cultures, as well as the application of appropriate technology.

Again, this system was introduced due to the difficulties faced in bringing water to this community in a conventional manner. There was a lot of opposition to the RWH technology in the area at first, as it was a technology that was not widely known in the area. Now, after 2 years using the rainwater falling on her roof, Mrs. Emsayakar, of Batalahena Village near the town Matara, sees things very differently.

The alternative offered by CWSSP was a handpump per 10 households. This still means walking to collect water. Mrs. Emsayakar joked that they can still use the handpump of their neighbours when they wish. She has not, however, had to do so yet as the harvested water meet all the needs of the family of 5, as long as they conserve water carefully. She also said, however, that she would prefer a piped / pumped supply which would mean that they could use as much water as they wish.

Technical detail

The tank

The tank is a 5m³ below ground cylindrical brick construction based on the design of a Chinese biogas digester (see Figure 1 below). It has a diameter of 2.5m and a height of 1.3m to the base of the cover. The cover is a constructed using a clever brick dome design which can be left open to provide access. Water extraction is either by bucket, by handpump or by gravity through a pipe / tap arrangement where the topography and ground conditions are suitable. The cost of the tank is in the region of Rps.6,500 (UK£100). The construction details given to local masons are given below.

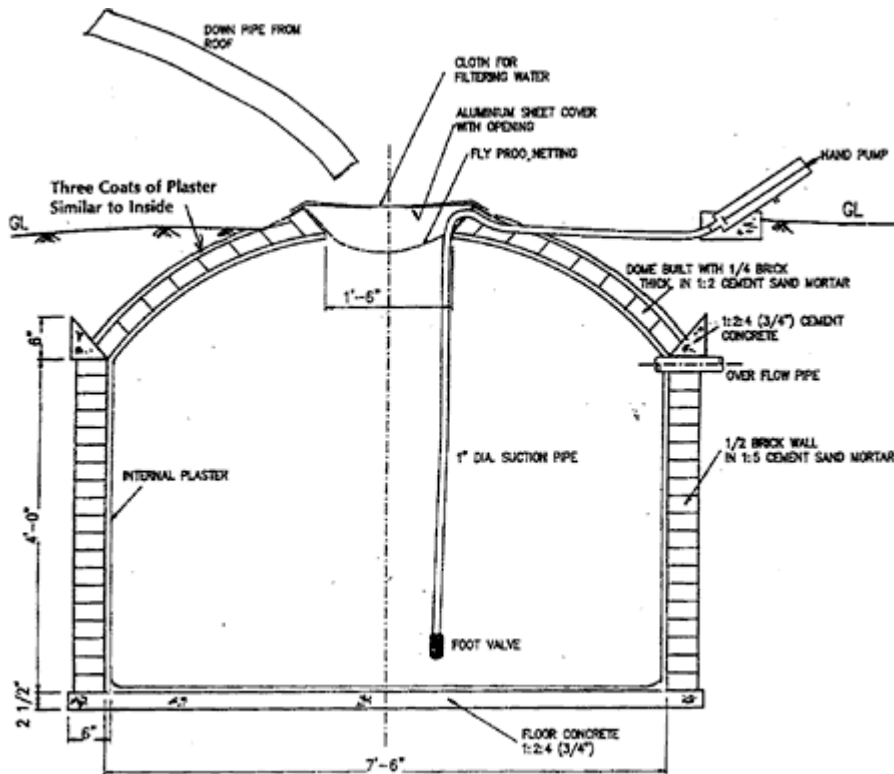

Figure 16: detail drawing of the Sri Lankan brick dome tank

The Sri Lanka Brick Dome Tank – Construction details

- Find suitable site
- Dig pit 0.5m larger than the tank diameter

- Plant an iron rod in the centre of the pit, making sure it is vertical.
- Construct concrete base.
- Start constructing walls using wire from iron rod to maintain the radius.
- Once walls are complete backfill the gap between wall and pit with sand.
- Make concrete ring beam to the shape shown. No reinforcing is required. Fit overflow pipe at this point if required.
- Prepare two wooden sticks – one end an 'L' shape and the other a 'V' shape. The length of the stick is 2/3 that of the internal diameter of the tank.
- Keeping the 'L' shaped end of the stick to top of the tank wall, place the 'V' end against the iron rod and wrap string or wire around the rod to support the stick.
- Start to build the dome shaped roof of the tank with dry bricks.
- To start, stick the first brick to the lintel with mortar and support it with the first stick.
- For the second brick, stick this to the lintel and the first brick and support it with the second stick.
- Push the third brick into place (with mortar) next to the second brick and move the second stick to hold the third brick.
- Continue the process as with brick 3 until the first course is almost complete.
- The final 'key' brick should be shaped to fit tightly allowing for the mortar.
- Remove the sticks once the first course is complete.
- Continue in this fashion for the subsequent courses.
- The dome mouth is constructed in a similar way, but using the bricks length-ways.
- Plaster the outside of the dome, then plaster the inside of the dome.
- Plaster the inside of the tank.
- Plaster the floor of the tank
- Cure the tank by wetting for 7 – 10 days. Fill the gradually starting on day 7, filling at a rate of approximately 300mm per day.



Water is extracted by means of a simple handpump which has been developed, as part of the CWSSP programme, for use with below ground tanks. The pump is known as the Tamana pump, after the Pacific island on which it's predecessor was originally observed (and used for bailing local fishing boats).

The Tamana pump is designed to be very low cost, approximately UK£5, using only locally available PVC fittings and rubber from a tractor inner tube. The location of the pump is shown in Figure 16. This particular pump was fitted by the owners son, a mechanic, who has fitted many of these pumps for other community members. The pump has been brought via a 3/4" PVC pipe to a point close to the kitchen of the house.

Figure 17: The Tamana pump installed at Batalahena

technical note

The catchment area is the roof of the dwelling. The guttering is a factory manufactured U section type fitted to a fascia board with specialist clips. Average annual rainfall is 2600mm with a bimodal rainfall pattern and a dry season which lasts for 3 months. When properly managed the water collected can last throughout the dry period, with occasional trips to the nearby well for washing water. The average consumption rate for the whole family is about 75 litres per day but this is reduced during the dry season. The water is used for all domestic applications and there is no anxiety about the quality of the water, as is seen often where rainwater is used.

Item	Unit	Unit cost	Quantity	Cost (SL Rupees)*
Cement	bag	310	8.5	2635
Sand	m3	1700	0.4	680
¾ " Metal bar	m3	4000	0.1	400
Brick	Number	2.1	800	1680
Padlo cement (for waterproofing)	kg	100	0.5	50
Skilled labour	days	250	4	1000
Unskilled labour	days	150	12	1800
			Total	8245

*(65 SL Rupees = Sterling £1.00 at the time of writing)

The unskilled labour is often provided by the recipient hence reducing the cost of the tank.

Case Study 3 – Cement mortar jar, 1.0m³ capacity

Introduction

This Case Study is taken from 'Rainwater Harvesting – The collection of rainfall and runoff in rural areas', Pacey and Cullis by IT Publications, 1986. Information has also been used from a recent EU funded Water and Sanitation Programme in Tanzania.

This type of water container was originally developed in Thailand but has also been used widely, often with modifications, in East Africa. Many variations on this type of tank have been developed over the years.



Figure 18 – 'Thai Jar' being built as part of a Water and Sanitation Programme in Tanzania

technical note

Construction details

The mould or formwork for a 1m³ cement mortar jar is made from 2 pieces of gunny cloth or hessian sacking, cut and stitched together with twine as shown in Figure 19. After sewing, the resulting bottomless bag is turned inside out.

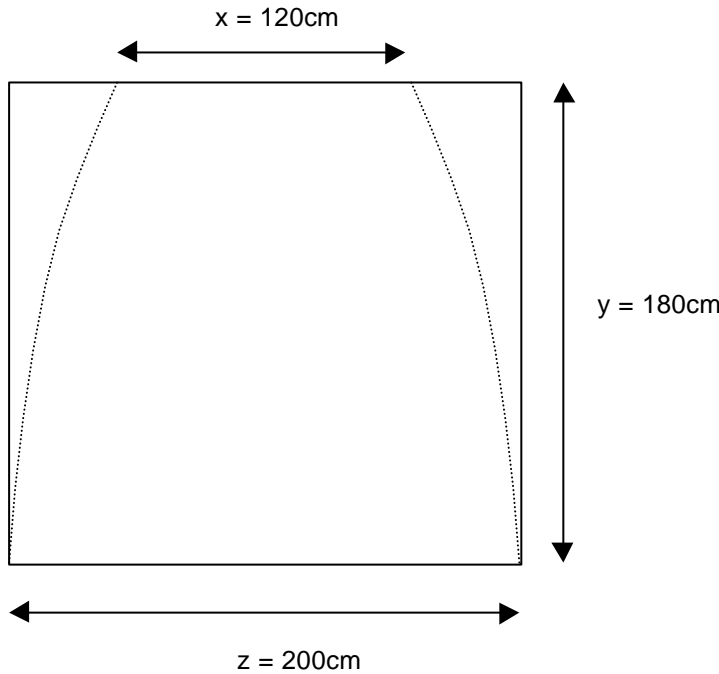

Figure 19: Dimensions for cutting sacking

- To make the bottom of the tank, mark out a circle on the ground of 1m diameter and place ½ bricks or other suitable material around its circumference to act as a formwork.
- Spread paper or plastic sheeting on the ground within the circle to stop the mortar sticking. Mix a 1:3 cement: sand mortar and spread within the circle to a depth of 15mm.
- When the bottom plate has set, place the sacking bag narrow end down on the plate and begin filling it with sand, sawdust or rice husks. Make sure that the mortar base sticks out from under the sack and tuck the edges of the sacking under the filling material, so that the weight of the filling holds the sacking on the plate.
- Fill the sack, fold the top and tie it closed. Then fold and smooth the sack into a regular shape. Make a circular ring from wood or cement mortar and place this on top as the formwork for the opening in the top of the jar.
- Spray the sacking with water until it is thoroughly wet, then plaster on the first layer of cement mortar to a thickness of up to 10mm.
- Plaster on the second 5 - 7mm layer in the same manner as the first, checking the thickness by pushing a nail in. Build up any thin spots.
- Remove the sack and its contents 24hrs after the plastering is completed. Repair any defects with mortar and paint the inside of the jar with cement slurry. Then cure the jar for 2 weeks protecting it from sun and wind under damp sacking.

General information

This type of jar can be manufactured in any size. However, as the tank size gets bigger the mould becomes unwieldy, and different methods have been devised for making the former. One such example saw the construction of 1.8m³ jars using specially made curved bricks to construct the formwork. The blocks are built into shape using mud as a temporary mortar and are then removed once the tank is complete. The formwork can then be reused again and again.

In East Africa, the use of chicken mesh between the first and second coats of plaster is a common addition which gives extra strength to the structure and helps prevent crack

technical note

propagation. This type of ferrocement tank can be loaded onto a truck for delivery, and therefore has the advantage that it can be made centrally for later distribution.

Watt, 1978, gives detailed instructions for the construction of a 0.25m³ jar in 'Ferrocement Water Tanks'. He suggests that similar tanks can be built up to 4m³ in size. The smaller mortar jars replace the traditional ceramic Thai jars and can be manufactured at about a tenth of the price. The quality of workmanship for this type of jar should be of high standard, as any flaws in the jar can quickly result in failure.

Material requirements

The quantities below are taken from a similar 1m³ jar used during a recent water and sanitation programme in Tanzania. This tank had reinforcing and a tap and a washout fitted.

Materials	Unit Price (TSh) 1997 Prices	Qty	COST (TSh)
Cement (bag)	6,200	2	12,400
Chicken wire (roll)	25,000	0.25	6,250
Binding wire (kg)	900	0.50	450
G.I Pipe 1" (m)	2,000	1	2,000
G.I F-F connectors 1"	300	2	600
G.I. Elbows	185	2	370
Locking Tap 1"	2,500	1	2,500
G.I. Male plug 1"	800	1	800
		Total	35,220

(2100 TSh. = £1 Sterling at the time of writing)

*sand and stone are not accounted for here as they were provided by the community as part of a self-help initiative.

** approximately 1 skilled and 1 unskilled person days are required per tank.

Case Study 4 – A typical European RWH system

Figure 20 shows a typical European RWH system. In Europe raw rainwater is used primarily for garden irrigation, toilet flushing or clothes washing. RWH systems are usually used to

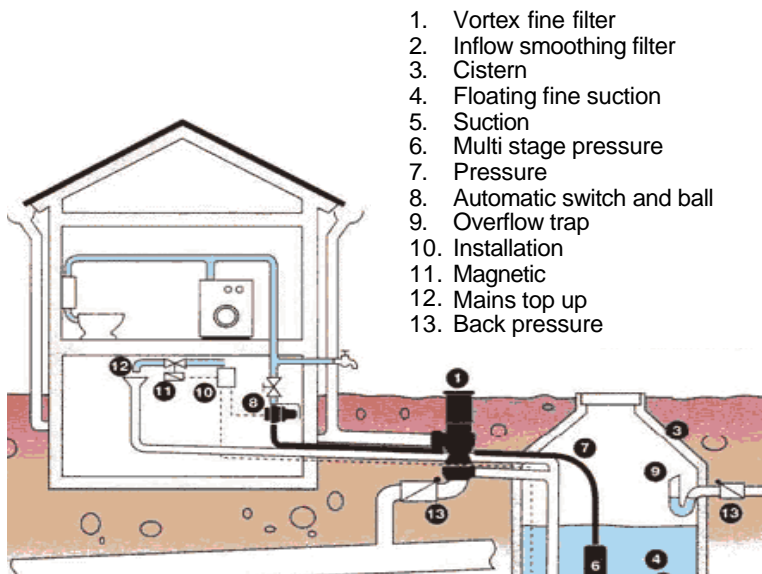

1. Vortex fine filter
2. Inflow smoothing filter
3. Cistern
4. Floating fine suction
5. Suction
6. Multi stage pressure
7. Pressure
8. Automatic switch and ball
9. Overflow trap
10. Installation
11. Magnetic
12. Mains top up
13. Back pressure

Figure 20: a typical European RWH system (Source: Construction Resources News, Winter 1997)

supplement the mains water supply. The move toward RWH in Europe has been driven by rising mains water costs and environmental awareness. The National water by-laws of most European countries put strict controls on RWH systems to prevent contamination of mains

technical note

supplies by rainwater or inadvertent drinking of rainwater (of unknown quality) by individuals. The mains and RW plumbing systems are kept separate and RW taps are clearly marked.

In Figure 20 we see a system with a below ground cistern (3) which feeds a pressurised secondary plumbing network within the house. A filter (1) removes any particles above 200 microns in size and the water then enters the cistern via a smoothing inlet (2) to prevent disturbance of sediment. A floating intake (4) prevents sediment being taken up from the cistern bottom into the piped network. A multi stage submersible pump (6) pressurises the water, which is fed to outlets for garden irrigation, and for toilets and laundry. A mains top-up system (12) operates automatically when the tank level drops below a predetermined level. Back pressure flaps prevent contamination of the rainwater tank from the sewerage or storm water systems in the event of the sewers backing up.

Rainwater Harvesting Resources

Books

- *Rainwater Catchment Systems for Domestic Supply*, by John Gould and Erik Nissen-Petersen, IT Publications Ltd., 1999. Summarises the state of the art at the moment.
- *Ferrocement Water tanks and their Construction*, S. B. Watt. 1978
The classic text on construction of ferrocement tanks.
- *Rainwater Harvesting: The Collection of Rainfall and Runoff in Rural Areas*, Arnold Pacey and Adrian Cullis – a wider focus including the capture of runoff for agricultural use. IT Publications.
- *Water Harvesting – A Guide for Planners and Project Managers*, Lee, Michael D. and Visscher, Jan Teun, IRC International Water and Sanitation Centre, 1992
- *Water Harvesting in five African Countries*, Lee, Michael D. and Visscher, Jan Teun, IRC / UNICEF, 1990. As snapshot of the status of RWH in five African countries.

Journals, Articles, Manuals

- Waterlines Journal Vol. 18, No 3, January 2000 and Vol. 14, No.2, October 1995 Both issues are dedicated to rainwater harvesting, available through ITDG Publishing,
- Photo-manuals by Eric Nissen-Petersen. A range of manuals on how to build a number of tank types including: cylindrical water tanks with dome, an underground tank, smaller water tanks and jars, installation gutters and splash-guards, available from the author at: P.O.Box 38, Kibwezi, Kenya.
- Rainwater Catchment Systems – Reflections and Prospects, John Gould, Waterlines Vol.18 No. 3, January 2000.
- Domestic Water Supply Using Rainwater Harvesting, by T.H.Thomas, Director of the Development Technology Unit (DTU), University of Warwick. The article is available on DTU's Web Site (see below).
- Waterlines back issues containing rainwater harvesting articles: Vols 17(3), 16(4), 15(3), 14(2), 11(4), 8(3), 7(4), 5(4), 5(3), 4(4), 4(3), 3(3), 3(2), 3(1), 2(4), 2(1), 1(1).

Video

- *Mvua ni Maji – Rain is Water, Rainwater Harvesting* by Women's Groups in Kenya, FAKT, 1996. 27 min VHS/PAL. A Kenyan film team documented this success story on the occasion of the visit of a delegation of Ugandan women who came to learn the skills of rainwater harvesting from their Kenyan sisters. Available through FAKT (see address section)
- *A Gift from the Sky – An Overview of Roofwater Harvesting in Sri Lanka* Available from the Lanka Rainwater Harvesting Forum (see address section).
- *Construction of Water Tanks for Rainwater Harvesting* – a video manual prepared by Eric Nissen-Petersen (see above).
- *Rock Catchments*. Several designs of rock catchment system looked at in detail. Again by Erik Niseen-Petersen.

technical note

Internet

<http://www.rainwaterharvesting.com> - a wealth of information on domestic RWH for developing countries, set up by the Roofwater Harvesting Research Group.

<http://www.eng.warwick.ac.uk/DTU/rainwaterharvesting/index.htm> - a number of case studies from around the world, with good descriptions.

<http://www.geocities.com/RainForest/Canopy/4805/> - software for sizing reliable rainwater harvesting systems with covered storage tanks – SimTanka, is freely available.

<http://info.lut.ac.uk/departments/cv/wedc/garnet/tncrain.html> - site of the Global Applied Research Network (GARNET) Rainwater Harvesting Page –

<http://www.unep.or.jp/ietc/Publications/TechPublications/TechPub-8d/index.html#1> - link to a recent UNEP publication titled 'Sourcebook of Alternative Technologies for Freshwater Augmentation in Small Island Developing States' that includes some useful information on RWH

<http://www.unep.or.jp/ietc/Publications/TechPublications/TechPub-8e/index.html>
Sourcebook of Alternative Technologies for Freshwater Augmentation in Some Countries in Asia - another in this series of UNEP publications

<http://www.wmo.ch/> - World Meteorological Organisation (WMO)

<http://ms2.pccu.edu.tw/~g8710704/> - International Rainwater Catchment Systems Association

<http://www.ufrpe.br/~debarros/APED/RWCpres/index.htm> - Rainwater Harvesting in the Loess Plateau of Gansu, China - a paper presented at the 9th IRCSA Conference in Brazil

<http://www.pastornet.net.au/worldview/ac.htm> -The Pelican Tank Rainwater Collection System - a packaged RWH collection system developed in Australia for use in developing countries

<http://www.greenbuilder.com/sourcebook/Rainwater.html#CSI> - Sustainable Building Sourcebook Website

http://www.idrc.ca/index_e.html - International Development Research Centre (Ottawa, Canada)

<http://www.greenshop.co.uk/> -The Green Shop (Stroud, UK – Rainwater Harvesting Systems)

<http://www.ait.ac.th/clair/centers/ific/> - International Ferrocement Information Centre, Thailand

<http://www.oneworld.org> - Oneworld Partnership - Links to many Development organisations

<http://www.irc.nl> – (IRC) International Water and Sanitation Centre

<http://www.sodis.ch/index.html> - SODIS - Solar Water Disinfection

<http://oneworld.org/cse/html/cmp/cmp43.htm> - Centre for Science and the Environment (CSE) rainwater harvesting page - a very active Indian Group

technical note

<http://www.sungravity.com/index.html> - The Sunstove Organization's web site provides free instructions, photos, drawings and specifications to build a roof catchment system, sand filter, cement water tank, and spring capping systems

<http://www.oneworld.org/itdg/> - IT Publications (Intermediate Technology Publications)

<http://takeyam.life.shimane-u.ac.jp/jircsa/homepage.html> - JRCSA (Japan Rainwater Catchment Association)

<http://www.sacentral.sa.gov.au/agencies/saw> - SA WATER (South Australian Water Corporation)

<http://www.sida.se> - SIDA (Swedish International Development Agency)

<http://www.ci.austin.tx.us/watercon/rainwater.html> - Texas Rainwater Harvesting Project

<http://www.oneworld.org/itdg/publications.html> - Waterlines

Useful addresses

- International Rainwater Catchment Systems Association (IRCSA), Dept. of Natural Resources, Chinese Cultural University, Hwa Kang, Yang Min Shan, Taipei, Taiwan. Email ufab0043@ms5hinet.net. Contact , Prof. Andrew Lo
- FAKT (Association for Appropriate Technologies), Kanalstr, 23, Weikersheim 97990, Germany. Email HansHartung@compuserve.com. Contact Dr Hans Hartung.
- fbr (German Rainwater Harvesting Association), Havelstr. 7A, 64295 Darmstadt, Germany. Email fbrev@t-online.de
- Lanka Rainwater Harvesting Forum (LRWF), c/o IT Sri Lanka, 5 Lionel Eridisinghe Mawatha, Colombo 5, Sri Lanka. Email rwhf@itdg.lanka.net. Contact Miss Tanuja Ariyananda
- Development Technology Unit, School of Engineering, University of Warwick, Coventry CV4 7AL, UK. Email dtu@eng.warwick.ac.uk. Contact Dr Terry Thomas. Also the co-ordinators of the Rainwater Harvesting Research Group (RHRG)
- Centre for Science and Environment (CSE), 41 Tughlakabad Institutional Area, New Delhi 110062, India. Email cse@cseindia.org. Contact Inira Khurana.
- People for promoting Rainwater Utilisation, 1-8-1 Higashi-Mukojima, Sumida City, Tokyo, Japan. Email murase-m@tc4.so-net.ne.jp. Contact Dr Makoto Murase
- IRC (The International Water and Sanitation Centre), PO Box 93190, 2509 AD, The Hague, Netherlands. Email general@irc.nl
- Uganda Rain Water Association (URA), P.O.Box 20026, Kampala, Uganda. Email: wesacc.dwd@imul.com. Contact Gilbert Kimanzi.
- Kenya Rainwater Association, POBox 72387, Nairobi, Kenya. Email kra@net2000ke.com. Contact Mr Julius Wanyonyi.

technical note